

# Alleghany Historical-Genealogical Society, Inc.

*Preserving Alleghany's Heritage Since 1979*



President . . . . . Roy Hunt  
 Vice-President . . . . . J.M. Sturgill  
 Secretary-Treasurer . . . . . Irene R. Wagner



Volume 32, No. 2

April 2011

Bulletin No. 102

## Congresswoman Foxx Visits AHM



*(L-to-R) Roy Hunt, Sharon and Jeff Halsey, Margaret Crouse, US Representative Virginia Foxx, Lucy Roe, Pauline Jolly and Patty Wingler.*

Congresswoman Virginia Foxx took time out of her busy schedule to stop by the museum, last month.

During her visit, Mrs. Foxx talked about an interesting book she was reading about Blanford and Dauphin Dougherty, brothers who founded Appalachian Training School for Teachers (now known as Appalachian State University). The book is *Mountain Educators* by Doris Perry Stam. She said she'd send it to us when she finished it and it was delivered soon after to the Society.

A long-time supporter of mountain heritage, Representative Foxx complimented members on the museum's progress and promised to come back when the exhibits change!



*(L-to-R) Lucy Roe, Pauline Jolly and Virginia Foxx.*

*Photos courtesy of Alleghany News & Rep. Foxx's website*

## Washing Machine & Wringer

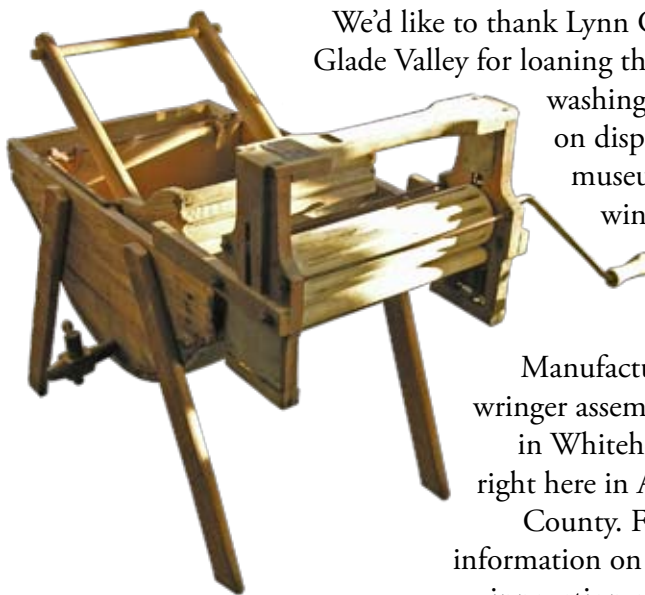

We'd like to thank Lynn Choate of Glade Valley for loaning the antique washing machine on display in the museum's front window. The device features a Dixie Manufacturing Co. wringer assembly made in Whitehead, NC-right here in Alleghany County. Find more information on this local innovation on page 3.

## Thank You, Sparta Teapot Museum!



The Alleghany Historical Museum has received a donation from the Sparta Teapot Museum! In February, two former members of the STM Board of Directors, John Brady and Sandy Carter-Herndon presented our president Roy Hunt and vice-president Jeff Halsey with this generous, unexpected gift of Twenty-Seven Hundred, Ninety-Two Dollars and Fifty-three cents for the museum.

*If you have information, photos or donations for our exhibit featuring the History of Alleghany Schools, contact the Museum at (336) 372-2115 (If unanswered, leave a message) or email us at info@ahgs.org*

## From the President

---

I would like to take a minute and say, thanks for all the hard work and support that you all have given the Historical Society and Alleghany Historical Museum. It has been one year now since we announced that we were going to have a Museum. If it was not for the help of you members and the public support we would not have what we have today.

We are taking old pictures that people have and scanning them in hopes of putting them into an archive so that we can preserve them. As time goes on we will use some of them in these newsletters. As you see we are showing some of them in each bulletin that we put out.

As the new year starts, it seems hard to believe that this concludes another year as president of the society. It is a reminder to me that we should make the most of all our opportunities in life because they pass with amazing rapidity. I wish to thank all those who have given direction and support to me during my tenure. It has been both an honor and a privilege to serve the Alleghany Historical-Genealogical Society, Inc.

Sincerely,  
Roy Hunt



*Alleghany Historical - Genealogical Society Board Members elected at our March meeting-  
Standing L-to-R: Marvie Shelor, Vice-President J.M. Sturgill, President Roy Hunt and Jeff Halsey  
Seated Wanda Cleary & Secretary/ Treasurer Irene Wagner*

## Grandpa Azariah Lyons- Mystery Solved?

---

My great-great-great-grandfather was Azariah Lyons from Virginia. He was born in 1823, married Zilpha Lundy, and had several children. He served in the Civil War in Company F of the 4th Virginia Infantry- the Grayson County Daredevils.

The family knew a lot about Azariah, his family, and his life in Grayson County, but nothing about his parents or how or when he came to Virginia. He seemed to have just appeared there one day sometime before 1850.

I decided to investigate him. On another family branch, I had a similar brick wall issue with an ancestor named Floyd Thomas. Later I found him as I. Floyd Thomas, then found Isaac Thomas. I thought that Azariah may have also gone by a different name as a child, so I started looking for spelling variations such as Ezra Lyons. But that went nowhere.

In a "site search" at newrivernotes.com, (they have a ton of information for Grayson and Alleghany Counties) I searched Lyon, and found an entry in the Grayson County's Early Orphans list (from either July

or August 1829), that said, "Ordered that the overseers of the poor bind Azuriah Lyon son of Nancy Lyon to Samuel Lundy as the law directs." Grandpa Lyons would have been just 6 years old in 1829.

More research revealed that the Samuel Lundy in Grayson County at that time was (likely) the second cousin of Zilpha's dad, John. If I'm correct in my findings, Azariah knew his future bride, Zilpha, while growing up.

I'd encourage everyone to start looking for their ancestors. Even people who claim they "don't know anything about it," know *something*. Everyone knows their parents' names at least. If you know your grandparents and your parents, you already know three generations.

If you have successful stories about breaking through brick walls or finding long-lost relatives, why not submit it to be included in the newsletter? Our society is the Alleghany Historical-Genealogical Society, after all. Send your stories to the Society at PO Box 817, Sparta, NC 28675 or [info@ahgs.org](mailto:info@ahgs.org).

Claire Halsey

## AHGS Launches New TV Show

The Historical Society has partnered with Alleghany Community Television to produce a new television series featuring Alleghany citizens who are 87 years or older.

The first episode of *Alleghany Memories*, the show's working title, has been shot and is in production at present. Sponsored by Friends of the Library, it features Mildred Torney and Pauline Jolly, both of whom were Alleghany County librarians (and charter members of the Historical Society.) Margaret Crouse interviewed the ladies about their lives, their work at the Society, and their years of service to the Library.

Pauline was Mildred's assistant when Mildred was head librarian and current librarian Debbie Brewer was Pauline's assistant when *she* was head librarian.

The shows last about an hour, and cost around \$150 to produce. If you or your organization would like to sponsor an episode or record a session with your own Alleghany Memories, contact Reba Evans, the Chair of the TV Interviews Committee, at 336-372-4866 for details. Participants each receive a copy of the program on DVD.

In addition to airing on Alleghany Community Television, the interviews will be available for purchase. The Society will sell DVDs for \$20 each.



(L-to-R) Mildred Torney, Margaret Crouse and Pauline Jolly at the Alleghany Community Television

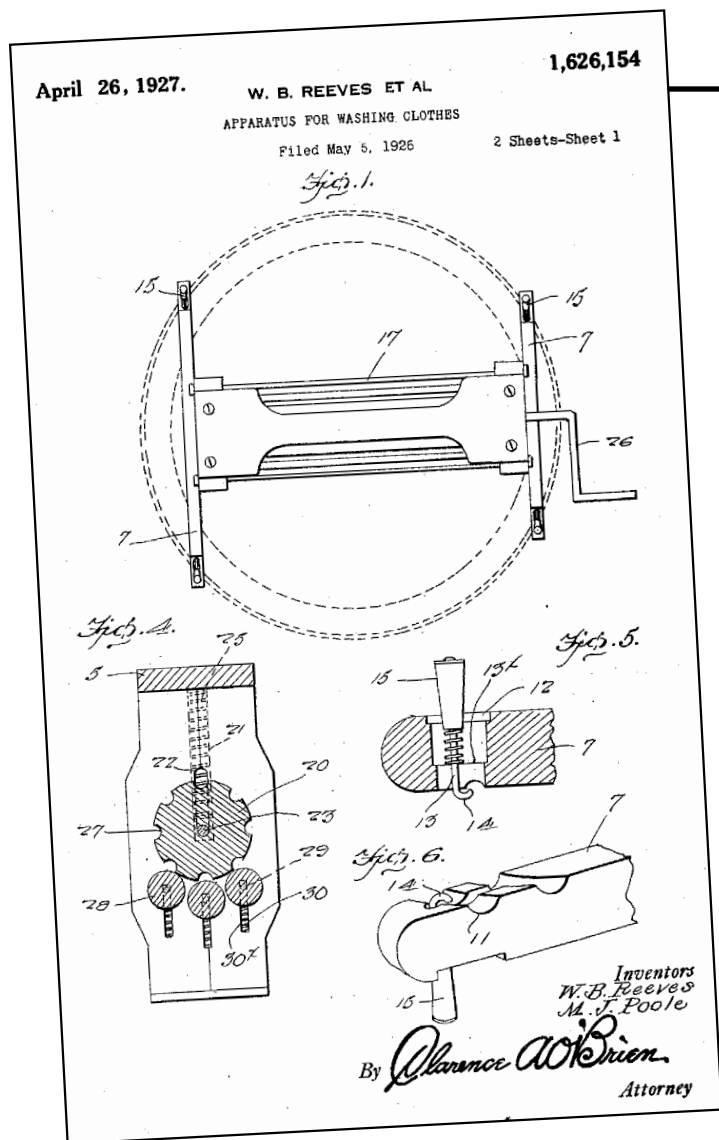

## Apparatus for Washing Clothes

May 5, 1926, William B. Reeves and Martin J. Poole (spelled as Martain on the patent) of Whitehead, NC filed a patent for their invention, APPARATUS FOR WASHING CLOTHES, which was "susceptible of quick and easy application" and able "to be operated with but a minimum amount of effort and one so operated to expedite the thorough cleansing of clothes."

Their invention was patented (#1626154) almost one year after it was filed, on April 26, 1927.



Clothes washing wringer assembly donated by Alease Moxley

## Sanders and Company Store in Downtown Stratford

*By Jean Sparks, Originally printed May 1, 1986 in The Allegheny News. Reprinted with permission.*

In the early 1920's the Stratford Community was the setting for a very prosperous and vital mercantile. Sanders and Company was a store owned and operated by Mack and his wife Carrie (Johnson) Sanders. Also for many years the Stratford Post Office was a part of this store.

Everything could be had at Sanders' store, or at least the people of that time thought so. Clothing of all types, farm and auto supplies, a complete line of groceries, hardware, and general household merchandise. Mack even bought and sold firs. Many people found the store to be an excellent gathering place, especially in the winter around their big wood stove. Mack and Carrie held the success of their store in their own warm and loving personalities. Many remember the "free hand-out policy" at the store. The many strangers and even often times neighbors that walked the road through the Stratford Community, would receive something to eat. Those depression years were hard felt in these mountain communities.

Mack was the son of John and Sarah Jane Sanders. Mack's father was a Primitive Baptist preacher at the nearby Antioch Church. Carrie was the daughter of Joseph and Winnie (Irving) Johnson. Mack and Carrie had two sons, Carlie and Johnson, and one daughter, Maxine. They also had eight grandchildren.

Mack was a very soft spoken man and enjoyed smoking a pipe. He taught school for many years. Carrie also held an interest in the academics. She would tutor students in her home in the art of public speaking. She would help write their speeches and many times through her guidance students would win prizes in local contests.

Carrie and Mack were among the first to have electricity and a bathroom in their community. It seems to have been the talk of the day, especially their classic claw foot bath tub. Carrie's wash house was another innovative creation. Mack had made a mechanism which controlled by a lever, allowed water to enter anytime to wash clothes.

Carrie enjoyed quilting and doing embroidery. In visiting with her granddaughter, Madeline Sanders Joines, I was shown a very beautiful embroidered picture of birds. The handwork was excellent. Another hobby Carrie enjoyed was writing poetry. 

*A post office existed for many years at the Sanders Store. This store was one of two stores that made up the center of the community. The other was first a garage run by Glen Richardson, then a store run by Frank Atwood and for some years a store operated by Isaac Richardson, whose wife, Rausa Sanders Richardson, later lived there.*



*Mack Sanders built his store in the 1920's and operated it for several years - this was a gathering place for the citizens, especially on Sundays. One such afternoon there was a large crowd gathered to watch Grover Napier go aloft in a huge hot air balloon; he descended faster than he had planned in a field near Highway 221, but was not seriously injured.*

*from History of Alleghany County, NC 1859-1976, available from AHGS. See page 5 for book information.*



*Mack Sanders, his wife, Carrie, and son, Charlie*

If you have items to loan or donate, stories to tell, photos to display or add to the database, or if you just want to volunteer, contact us at [info@ahgs.org](mailto:info@ahgs.org). The Museum Committee would love to hear from you. Got an idea for a display? Give us a call!

Contact Pauline Jolly at (336) 363-2282, leave a message at 336-372-2115 or email us at [info@ahgs.org](mailto:info@ahgs.org).

If you've been thinking about giving this year, please consider the Historical Society. The Alleghany Historical - Genealogical Society is a 501(c)(3) non-profit organization, so all contributions are tax deductible.

If you'd like to volunteer or contribute to the Alleghany Historical Museum, contact us at:

**Alleghany Historical - Genealogical Society**  
336-372-2115, P.O. Box 817, Sparta, NC 28675.

### Books For Sale

**HISTORY OF ALLEGHANY COUNTY, NC 1859-1976** - 272-pages not indexed - \$45,

S&H \$3 NC residents \$3.04 tax.

**ALLEGHANY COUNTY HERITAGE** - 555-pages indexed - \$48, S&H \$3 NC residents \$3.24 tax.

**ALLEGHANY COUNTY CEMETERIES THROUGH 1986** - 261-pages - \$15, S&H \$2.75

NC residents \$1.01 tax.

**ALLEGHANY ARCHITECTURE: A PICTORIAL SURVEY** - 101-pages not indexed -

\$30.00, S&H \$3.00 NC residents \$2.03 tax.

**ALLEGHANY COUNTY, NC MARRIAGES: 1849-1900** - 354-pages indexed - \$32.00 plus \$4

S&H from Heritage Books Inc., 100 Railroad Ave., Ste 104, Westminster, MD 21157 1-800-876-6103

[www.heritagebooks.com](http://www.heritagebooks.com).

**ALLEGHANY COUNTY COURTHOUSE ORNAMENT** - Gold-colored metal ornament depicts

the county courthouse. \$11.21 NC residents \$0.76 tax; no shipping & handling.

**MARY'S MEMORIES** - 74-pages Published by Mary Lyon Harless in 2000 on the occasion of her 100th

birthday. \$8.00, S&H \$1.50 NC residents \$0.54 tax.

**FOOT PRINTS ON THE SANDS OF TIME** - 75-pages Subtitled "A History of Southwestern

Virginia and Northwestern North Carolina," first published in Sparta, NC in 1900 by Dr. Aras B. Cox. Indexed.

\$15.00, S&H \$2.00 NC residents \$1.01 tax.

**1938 VIDEO OF SPARTA, NORTH CAROLINA** - 20-minute video, by Ben Reeves - Trip to the

1939 Worlds Fair in New York, with 1938 Sparta. VHS tape or DVD \$11.00, S&H \$1.50 NC residents \$0.68

tax.

**RECIPES THAT RAISED US** - 230 pages Memorial cookbook \$20, S&H \$3.00 NC residents \$1.35

tax or (3) books for \$45.00, S&H \$7.00 NC residents \$3.04 tax.

Find all our items online at: [www.spartastore.com](http://www.spartastore.com)

Or to order directly from the Society, send your check, payable to Alleghany Historical-Genealogical Society, to:

**Alleghany Historical-Genealogical Society, P.O. Box 817, Sparta, NC 28675.**

[info@ahgs.org](mailto:info@ahgs.org)

336-372-2115

[www.ahgs.org](http://www.ahgs.org)



### Membership Form

Please enroll me as a member of the Alleghany Historical-Genealogical Society, Inc. in the classification below:

New  Renewal

Individual \$10.00 annually

Business, Institutional or professional \$20.00 annually

Sustaining \$ 50.00 annually

LIFE MEMBER \$100.00 in one payment

Enclosed is a check or money order for membership.

Please send membership card to:

Name-\_\_\_\_\_

Address-\_\_\_\_\_

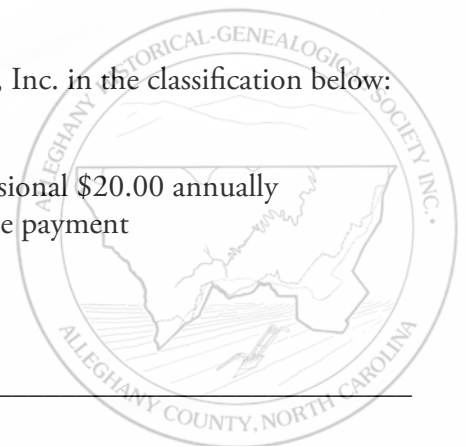

## Inquiries

---

Inquiries are printed here and posted online at [ahgs.org](http://ahgs.org). If you are looking for information, you can mail your question to P.O. Box 817 or email [info@ahgs.org](mailto:info@ahgs.org). Also, if you have answers or information for these people, contact them!

I've been researching my family tree for several years now. I've seen things in my research about Edwards Cross Roads, and the old Zion schoolhouse. Where are these places located? I've probably been by these places & didn't know what I was looking at!  
*Leanne Evans, PO Box 1054, 1137 Grandview Drive, Sparta, NC 28675, 336-372-4029, Best Time to Call: 12n - 5p, [leanne@lce.net](mailto:leanne@lce.net)*

---

My name is Mike Carter. I live in Rocky Mount VA. I am a direct descendant of John Jack Mays, "The Last Man Hung In NC" I am doing genealogy work on this side of my family and looking for other descendants of the Mays/Mayes. I would welcome any information or comments on the subject. Even though these ancestors lived at Devotion in Surry County NC, there were some connections to Alleghany county. Thank you in Advance,  
*Mike Carter, 400 Old Franklin Turnpike, Suite 117, Rocky Mount, VA 24151, 540-483-0779 Best Time to Call: 12n - 5p, [mikeandchris.carter@gmail.com](mailto:mikeandchris.carter@gmail.com)*

---

I'm trying to locate a copy of a document or Bible record that shows Thomas Hash is the son of William Horton Hash, Jr. They are my 5th and 6th great-grandfathers. I will appreciate any help. Thanks,  
*Hobert Halsey, 127 Cherry Tree Lane, Elkton, MD 21921 [rebelmanIII@yahoo.com](mailto:rebelmanIII@yahoo.com)*

---

We're looking for information on Mahala Anderson, born c.1822. She married Elijah Frances, 1816-1883 the son of Charles Frances, born 1765 and Sarah (?). Mahala's daughter was Elizabeth Frances, 1843-1913, married Robert Franklin Halsey. They lived in Ashe & Alleghany Counties.  
*Claire Halsey, PO Box 533, Sparta, NC 28675*

Can anyone tell me the history of the town of Scottville? I have ancestors from the area, Cranberry, Ashe County, pre 1810. I have a confirmed ancestor, Larkin, born there in 1809, and I think his dad was Solomon, but I cannot make the connection. Any help would be appreciated. Especially any ties to Scottville.  
*Heather Jo Bailey, Nora Springs, Iowa, 641-749-5252, Best Time to Call: 8a - 12n, [montecarlo2k@gmail.com](mailto:montecarlo2k@gmail.com)*

## Museum Gaining Notoriety

---

The opening of the Alleghany Historical Museum was featured in the Federation of North Carolina Historical Societies' May bulletin: "As noted on its website, the Alleghany Historical-Genealogical Society has for many years collected and preserved historical items such as photographs, paintings, artifacts, furniture, work implements, and other materials which illustrate the life, conditions, events, and activities of the past and present. The society has long hoped to have a museum to store, study, and display these objects.

"This new museum is based in a former Belk's building at 7 North Main Street in downtown Sparta. This building will serve as a temporary home for the museum until a permanent location can be found."



*Caldwell Heritage Museum, Lenoir, NC*

Later, we received a note from John O. Hawkins, the Museum Director at Caldwell Heritage Museum:

"I just read in the Federation of North Carolina Historical Societies bulletin about the opening of your Museum. Congratulations!

"We have added you to our mailing list and we would appreciate hearing from you. Also we hope to visit you in the near future. Please come by to visit us if you're ever in Lenoir."

The Caldwell Heritage Museum is located at 112 Vaiden Street SW in Lenoir, NC.

Phone: (828)-758-4004 and  
web: [www.caldwellheritagemuseum.org](http://www.caldwellheritagemuseum.org).

# What's ~~New?~~ Old



*Small flax spinning wheel  
loaned by the Halsey family*

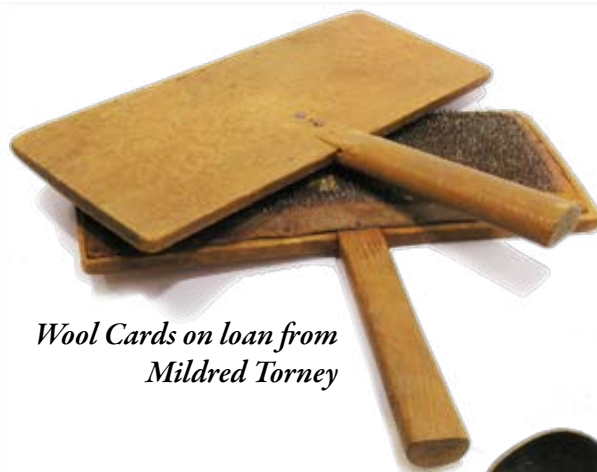

*Wool Cards on loan from  
Mildred Torney*



*"Double Bow" Sheep-shears  
donated by Bob Black*



*Ladies' Iron Side-Saddle  
Stirrup from Ernest &  
Agnes Joines*



*Martin Brinegar's shoe  
lasts donated by  
Sharon & Leland  
Simons*

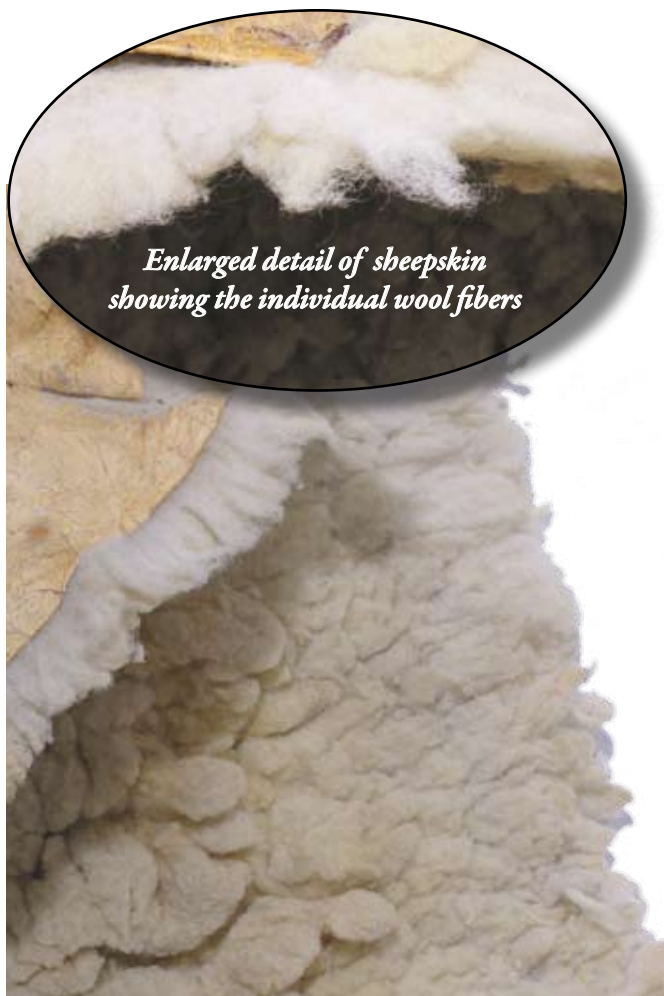

*Enlarged detail of sheepskin  
showing the individual wool fibers*

*Sheepskin from  
a ewe that died after  
eating mountain laurel  
in early Spring of 1957  
donated by Sharon & Leland  
Simons*

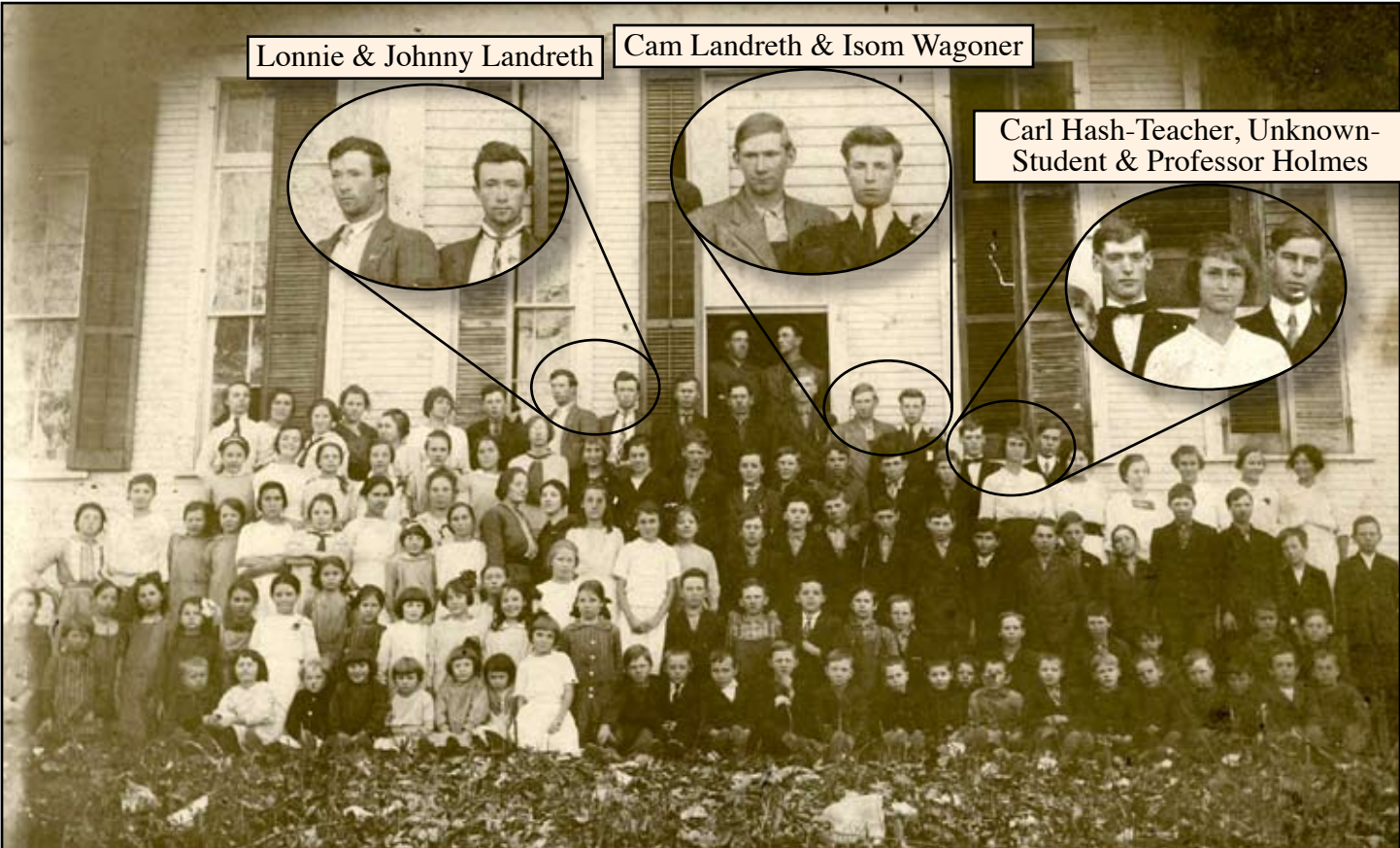

Lonnie & Johnny Landreth

Cam Landreth & Isom Wagoner

Carl Hash-Teacher, Unknown-Student & Professor Holmes

*Photo of Turkey Knob School group- Date unknown- Other names in photo: Annie Gamble, Virginia Wagoner, Cora Wagoner, Thelma Parsons, Bruce Wagoner, Clyde Wagoner, Olie Wagoner, Olie Parsons Buren Landreth. Original photo from Bruce Wagoner and donated by Lois Landreth. Can you help identify anyone here? Contact us!*

The Alleghany Historical - Genealogical Newsletter is published by Imaging Specialists, Inc., P.O. Box 533, Sparta, NC 28675  
 www.imagingspecialists.net - To see back issues of this newsletter, go online to www.ahgs.org.

*Remembering Alleghany for Over Thirty Years*

Alleghany Historical-Genealogical Society, Inc.  
 P.O. Box 817  
 Sparta, NC 28675